

**Frozen**  
**Frozen granita and cream dispenser**  
**with 1 bowl, UK plug and UV light**

ITEM # \_\_\_\_\_

MODEL # \_\_\_\_\_

NAME # \_\_\_\_\_

SIS # \_\_\_\_\_

AIA # \_\_\_\_\_



560102 (SPINewUK)

\* NOT TRANSLATED \*

### Main Features

- Ideal for the production of chilled specialties: creamy desserts, sorbet, mousses and similar products.
- Works with water or milk/based dried products or with brik mixtures ready to be poured into the bowl.
- Perfect solution for bars, restaurants, cafeterias, coffee shops, hotels and all the other HoReCa operators who desire reliable piece of equipment.
- The machine automatically stops when the cover is opened.
- No more ice or condensation outside the tank with the insulated tank.
- Rounded shapes with stainless steel finishing and white plastics.
- The insulated tank guarantees higher cooling efficiency and lower effect of the external temperature on product's preparation and maintenance time reducing condense and draining; it is the best solution in hot climate conditions.
- New design of the screw to adjust the product consistency makes the equipment extremely user-friendly.
- Hybrid control of consistency. The integrated software allows the equipment to self-adjust to ensure that the product has always the same consistency, from the first to the last drop dispensed.

### Construction

- All parts that come into contact with the food are in stainless steel or plastic, can be removed for easy cleaning and are dishwasher safe.
- Compact design.

APPROVAL: \_\_\_\_\_



**Electrolux**  
PROFESSIONAL

## Frozen Frozen granita and cream dispenser with 1 bowl, UK plug and UV light

Front

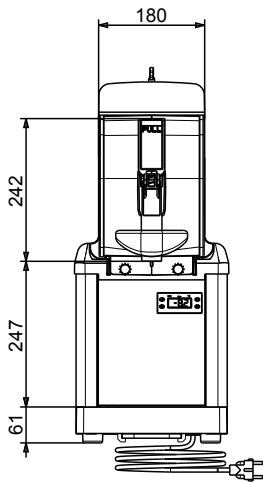

Side

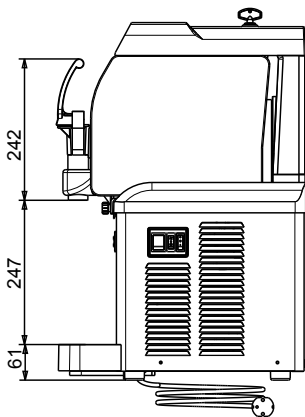

Top

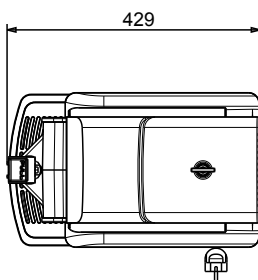

### Electric

Supply voltage:

560102 (SP1NewUK) 220-240 V/1 ph/50 Hz

Electrical power max.:

0.28 kW

### Key Information:

External dimensions, Width: 262 mm

External dimensions, Depth: 429 mm

External dimensions, Height: 613 mm

Net weight: 28 kg

### Sustainability

Refrigerant type: R290

Refrigerant weight: 68 g



Frozen  
Frozen granita and cream dispenser with 1 bowl, UK plug and UV light

The company reserves the right to make modifications to the products without prior notice. All information correct at time of printing.

2024.12.22